

* Modification of the Multi unit abutment

✓ AnyRidge

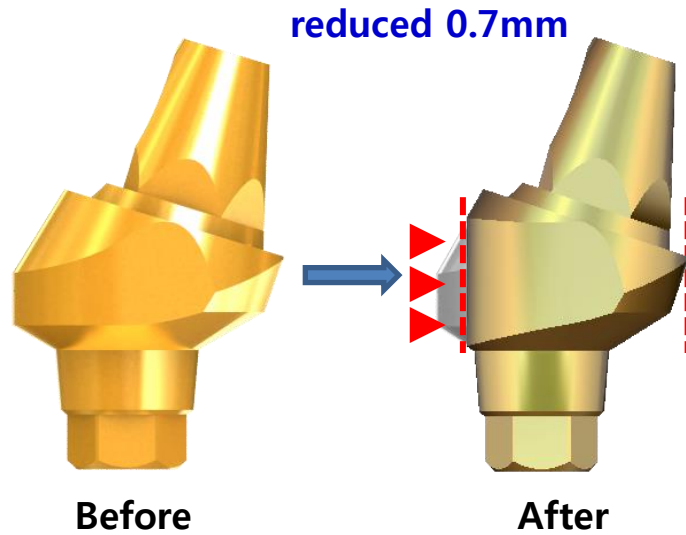

17degree

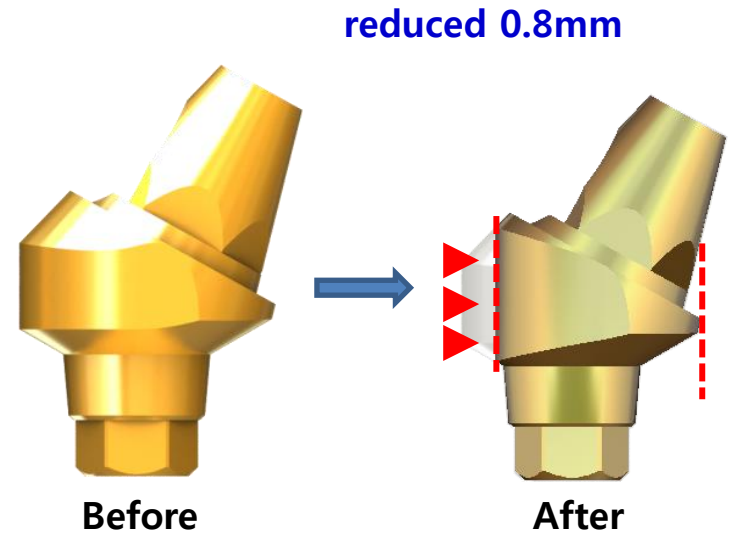

29degree

1) 17degree

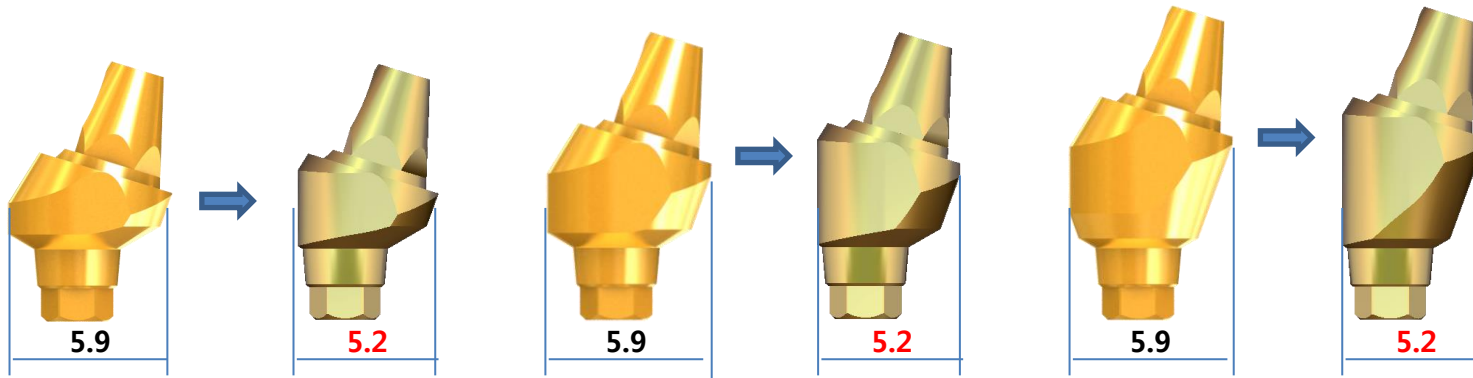

Ref. C ;
AANMUH50317T(Hex)
AANMUN50317T(Non-Hex)

Ref. C ;
AANMUH50417T(Hex)
AANMUN50417T(Non-Hex)

Ref. C ;
AANMUH50517T(Hex)
AANMUN50517T(Non-Hex)

2) 29degree

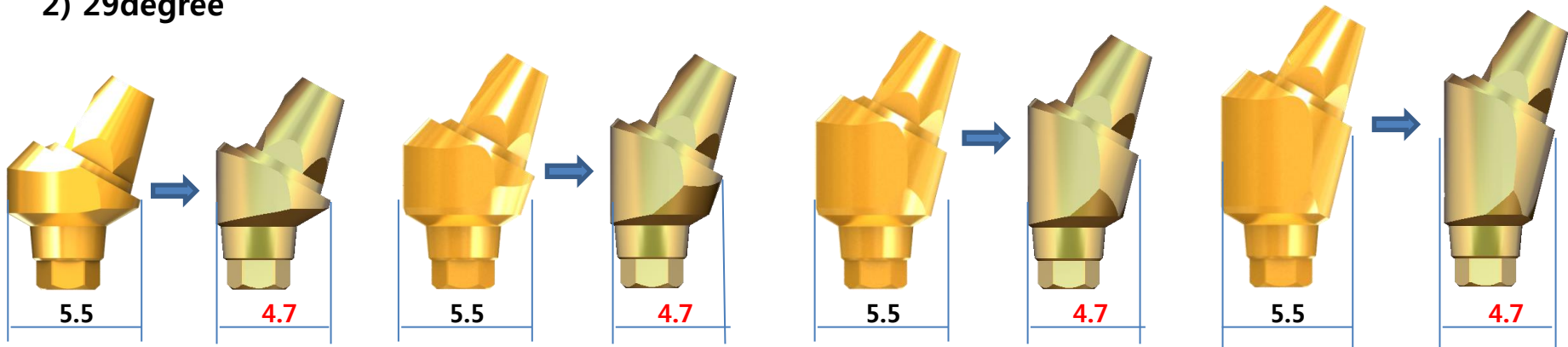

Ref. C ;
AANMUH50329T(Hex)
AANMUN50329T(Non-Hex)

Ref. C ;
AANMUH50429T(Hex)
AANMUN50429T(Non-Hex)

Ref. C ;
AANMUH50529T(Hex)
AANMUN50529T(Non-Hex)

Ref. C ;
AANMUH50629T(Hex)
AANMUH50629T(NON-Hex)

✓ AnyOne

Impossible to produce
Because of the structure

17degree

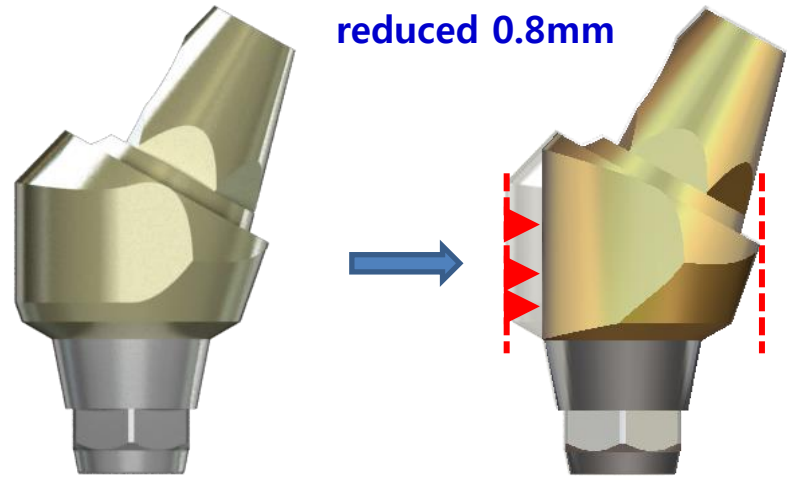

29degree

1) 17degree

**Impossible to produce
Because of the structure**



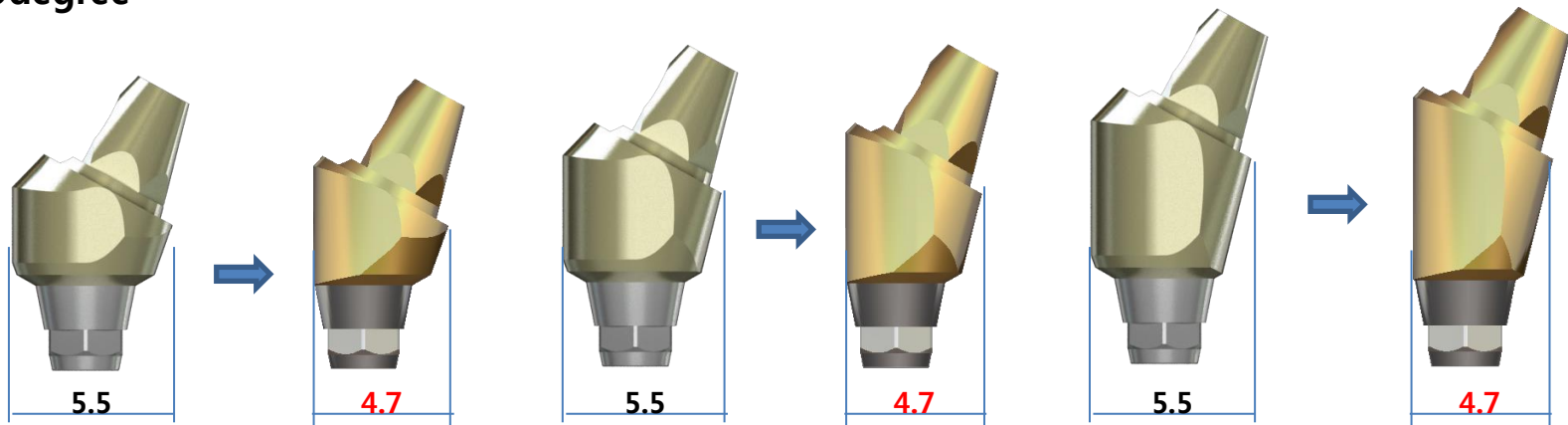











2) 29degree

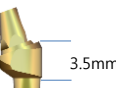
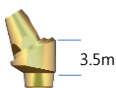

Ref. C ;
MU50429HT(Hex)
MU50429NT(Non-Hex)

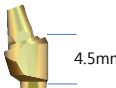
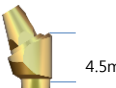
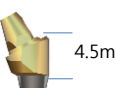
Ref. C ;
MU50529HT(Hex)
MU50529NT(Non-Hex)

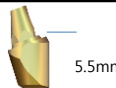
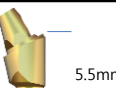
Ref. C ;
MU50629H((Hex)
MU50529NT(Non-Hex)

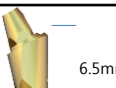
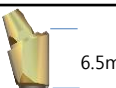
	NobelActive_ 17°/30°		NobelReplace_ 17°/30°		AnyRidge_ 17° /29°		AnyOne_ 17° /29°	
	Internal conical connection NobelActive™ 		Internal tri-channel connection NobelReplace™, Replace™ Select, NobelSpeedy™ Replace 		AnyRidge Internal 		AnyOne Internal 	
C2	X	X	 2mm	X	X	X	X	X
C2.5	 2.5mm	X	X	X	X	X	X	X
C3	X	X	 3mm	X	X	X	X	X
C3.5	 3.5mm	 3.5mm	-	X	 3.5mm	 3.5mm	X	X
C4	X	X			X	X	X	X
C4.5	X		 4mm	 4mm	 4.5mm	 4.5mm	X	 4.5mm
C5	X	 4.5mm	X	 5mm	X	X	X	X
C5.5					 5.5mm	 5.5mm	X	 5.5mm
C6					X	X	X	X
C6.5					X	 6.5mm	X	 6.5mm